



FLUID METERING, INC.
 5 AERIAL WAY, SUITE 500, SYOSSET, NY 11791
 800-223-3388 • 516-922-6050 • FAX 516-624-8261
<http://www.fmipump.com>

**"SCST-01" STEP MOTOR
 CONTROL KIT
 OPERATION INSTRUCTIONS**

New FMI Step Motor Control Kit "SCST-01"

Congratulations! Your FMI Step Motor Control Kit SCST-01 is a complete control package designed specifically for FMI pumps with step motors. It's small in size but big in performance and provides a quick method to run your pump today.

Quick Start Instructions

Your controller is initially set to provide 320 strokes/minute or 150 strokes/minute. Dispense and other speed settings are easily set by following the detailed instructions on the following pages.

1. Connect harness J1 & J2 to appropriate connectors on board. The black and white wires from J1 connect to the power supply. White (or black with white lettering) is the positive lead while solid black is negative.

*Connect DIP Switch Assembly to Header J3 (Pin 1 to red stripe)

DO NOT TURN POWER ON

2. Connect motor wires to terminal block J1 according to the following chart:

Table1.

Screw Terminal Color	Motor Phase	Motor Lead Color for Standard STRH/STH/STQ/SQ pumps		STRH/STH/STQ/SQ Duplex
		Motor P/N 110746 (NEMA 23 Frame)	Motor P/N 110745 (NEMA 17 Frame)	Motor P/N 300615 (NEMA 23Frame)
Yellow	\bar{A}	Yellow and Black	Yellow	Orange & White w/Black Stripe
Red	A	Red and White	Red	Black & White w/Orange Stripe
Brown	\bar{B}	Blue and Orange	Orange	Yellow & White w/Red Stripe
Orange	B	Green and Brown	Blue	Red & White w/Yellow Stripe

3. Connect pump sensor leads to J2 according to color i.e. Red to Red, etc.
4. Turn on power and pump will start running at factory setting. Note: See 4.1 page 6.
 *Basic Boards use jumper pin connector shunts instead of DIP switch.

1.0 Description



The SCST-01 is a self-contained step motor controller specifically designed for use with Fluid Metering pumps. It contains its own step drivers and can be set to several run modes utilizing either internal or external controls.

1.1 Features

- Pre-set Run Modes
- Multiple Control Methods: PLC, Relay, 0-5 VDC, or Manually by shunt
- Dispense, Run
- Sensor Enable/Disable
- Switchable Forward/Reverse of Motor Direction

2.0 Run Modes

The SCST-01 step motor controller can be used to drive any FMI stepper driven (STH, STQ) pumps in any of the following modes.

2.1 Continuous (Constant Run) Mode

Your Kit comes factory set for 320 or 150 spm (strokes per minute). Speed is easily adjustable using shunt connectors on Speed Header J3 (fig. 1) or DIP Switch Assembly. Speed is adjustable using Pins (Switch) 1-7 and binary addition according to the following chart and diagram or by 0-5 VDC input (Section 2.4).

Figure 1

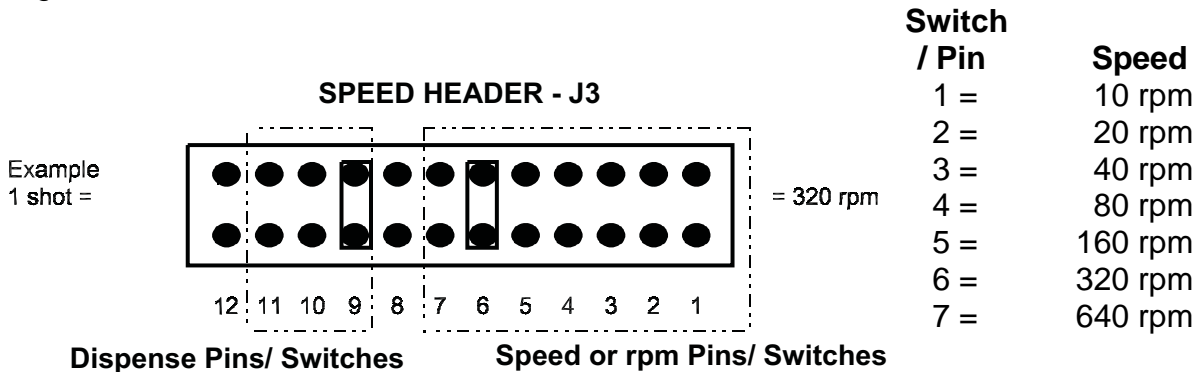

2.2 Dispense Mode

The system will allow you to dispense from 1 to 7 shots per signal (momentary switch closure on J2). The number of shots per signal is set by shunting pin/Switches sets 9-11 on Header J3.

Pin/Switch No.= # of shots **Example**



Pin 9 = 1
 Pin 10 = 2
 Pin 11 = 4

Pin 9 + Pin 11 = 1 + 4 = 5 shots

2.21 Actuation For Dispense

Dispense Actuation is handled by Pins 3 & 4 on the J2 Terminal Block by providing a momentary contact (switch closure, PLC, Relay, Mechanical Timer) of the 2 yellow wires. The minimum closure time that this input can see is 30 milliseconds (0.030 sec). **DO NOT APPLY ANY VOLTAGE** to this input!

2.3 Timed/Count Dispense (Pin Shunt use only)

The pump will begin dispensing until both pins of pin set 9 on J3 are shorted together. This will cause the pump to stop. Pin set 9 can be shorted by using any counter or timer that can control a SPST type relay or switch closure. External counters can tap pin 8 on J2 to sense the count pulse.

Typical wiring is as follows:

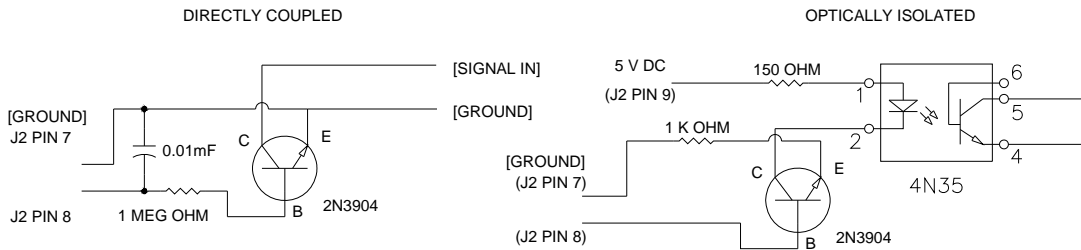

2.4 External Control 0-5 VDC - Voltage Following Input

In order for the stepper controller board to recognize and accept a 0-5 VDC control input all shunts on pins 1-7 (header J3) must be removed or Switched off. The board will *not* respond to a voltage input if any of the speed select pins have a shunt across them. Once the shunts on all pins are removed, a DC voltage signal may be applied to header J2 pins 1 and 2 and a variation of that voltage will linearly vary the motor speed. Maximum speed using a 0-5 VDC input signal is limited to 1200 rpm, depending on the application. For duplex motor P/N 300615, the max speed is 150rpm.

3.0 Input Headers

The SCST-01 step motor controller has several different input/output header sections for control and interface with the stepper motor. A diagram showing the placement of these headers can be found in Figure 2.



A single 24VDC power supply delivering 1.25A (min) of current is required for driving any of the standard Fluid Metering step motors (inputs 1 and 2 on Header J1).

3.1 POWER Header - J1

The POWER header section (J1) is used for input power and output to the stepper motor phases. This is a 0.156" pitch 6 pin header connector which has the following pinout:

Pin #

1. Power supply minus lead (V-) connection.
2. Power supply plus lead (V+) connection.
3. Connection to phase B of the stepper motor.
4. Connection to phase \bar{B} (B bar) of the stepper motor.
5. Connection to phase A of the stepper motor.
6. Connection to phase \bar{A} (A bar) of the stepper motor.

3.2 CONTROL Header - J2

The CONTROL header section (J2) is used for optical sensor connections, 0-5 VDC controls and dispense controls. This is a 0.100" pitch 9 pin header connector. The pinout for this header is as follows:

Pin #

1. 0-5 VDC Common
2. 0-5 VDC Signal Input
3. Start Pulse Common
- 4.* Start Pulse Signal Input (for dispense, controlled by momentary switch to ground)*

	Hall Effect sensor	Opto Sensor 110569	Opto Sensor 300696
5.		Emitter Cathode (black)	
6.		Emitter Anode (red)	
7.	Detector Ground (green) / Power Supply Ground	Detector Ground (green) / Power Supply Ground	Detector Ground (black) / Power Supply Ground
8.	Detector Signal (blue)	Detector Signal (blue)	Detector Signal (white)
9.	Power +5 VDC (white)	Power +5 VDC (white)	Power +5 VDC (red)

NOTE: The colors listed for sensor leads are for the standard sensors supplied with FMI pumps. Other sensors may have other lead color configurations.

***Note: DO NOT APPLY ANY VOLTAGE TO THIS INPUT!**



3.3 SPEED Header - J3

The SPEED header section (J3) is used for speed settings, number of dispense settings, and switching between stall detect (sensor) and non-sensor mode. This is a dual row 0.100" pin header. Functions are actuated by means of connecting pins using industry standard shunts or by DIP Switch Assembly. This header contains the controls for speed settings, stall detect enable, and number of dispenses. The pinout for this connector is as follows:

1. Speed - 10 rpm
2. Speed - 20 rpm
3. Speed - 40 rpm
4. Speed - 80 rpm
5. Speed - 160 rpm
6. Speed - 320 rpm
7. Speed - 640 rpm
8. Sensor detect on/off - The default (no shunt) is sensor enabled (See page 1 item#4).
9. Dispense - 1 dispense
10. Dispense - 2 dispenses
11. Dispense - 4 dispenses
12. CW/CCW - The default (No Shunt) CW Rotation
13. Not Used.

These pins are set up as a binary system. This means that multiple pins shunted will add their values together. For example, to set the motor to run at 500 rpm you must shunt pin pairs Switches 6, 5, and 2 ($320+160+20=500$ rpm). The shunts can give a maximum speed of 1270 rpm and 7 dispenses. (see page H1 item # 4) The controller will run at constant speed until one of the dispense setting pairs are shunted.

The motor will then home itself to the proper starting point and begin the desired number of dispenses upon connection of the Start Pulse Signal and the Start Pulse Common pins (Header J2, pins 3 and 4) by means of a momentary switch.

3.4 Header – J4

This Header is for internal FMI use only. It has no function to control the Driver Board.



4.0 Features

4.1 Trim Pot

Factory set at (approx.) For motors P/N 110746, 300615 the trim pot is factory set at 1.75 amp/phase. The trimming potentiometer (see Figure 2 for approximate location) is used to limit the amount of current used by the controller in driving the stepper motor. Turning the potentiometer clockwise will provide more current to the motor, while turning it counter-clockwise will reduce the current supplied.

Figure 2

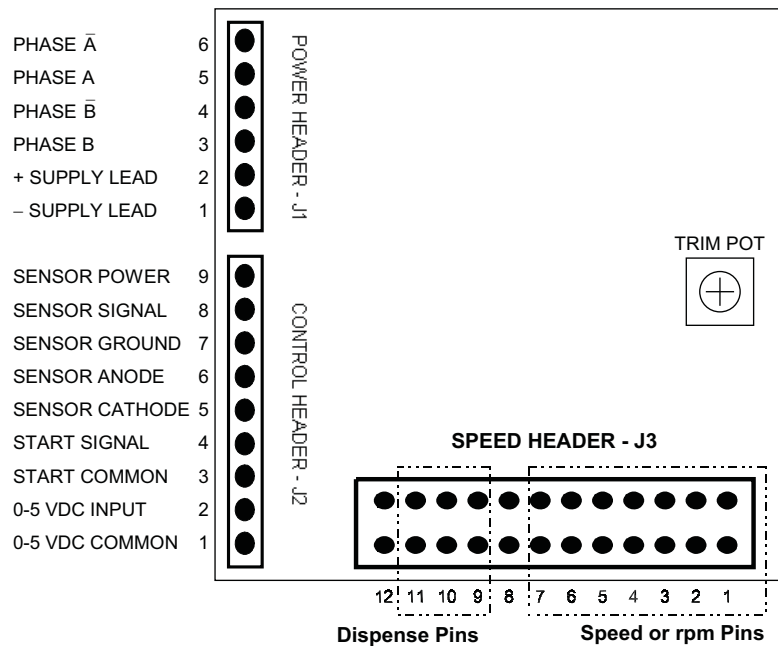

IMPORTANT

Additional heat sinking may be required when operating above 2.5 amps per phase. Contact factory for additional information.



**"SCST-01" STEP MOTOR
 CONTROL KIT
 OPERATION INSTRUCTIONS**

USE AMP METER 5 AMP FULL SCALE **

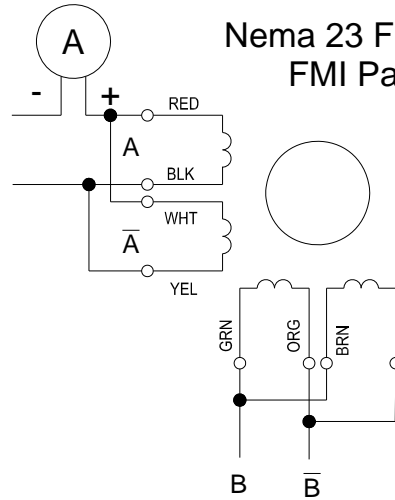

**Nema 23 Frame (2.2 inch square)
 FMI Part Number 110746**

** Adjust motor current trim pot as required.
 Do not exceed maximum motor rated current
 of 3.5 Amps per phase.
 Higher speed values can be achieved with
 a 30 VDC 4 amp minimum power supply.

Pin # J1----POWER HEADER

Screw Terminal Color	Motor Phase	Motor Lead Connection
6 Yellow	A	Yellow-Black
5 Red	A	Red-White
4 Brown	B	Blue-Orange
3 Orange	B	Green-Brown

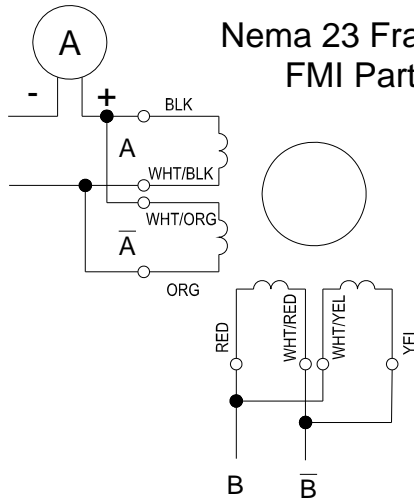

**Nema 23 Frame (2.2 inch square)
 FMI Part Number 300615**

(DUPLEX DRIVE MAX SPEED 150 RPM)

** Adjust motor current trim pot as required.
 Do not exceed maximum motor rated current
 of 3.5 Amps per phase.
 Higher speed values can be achieved with
 a 30 VDC 4 amp minimum power supply.

Pin # J1----POWER HEADER

Screw Terminal Color	Motor Phase	Motor Lead Connection
6 Yellow	A	ORG-WHT/BLK
5 Red	A	BLK-WHT/ORG
4 Brown	B	YEL-WHT/RED
3 Orange	B	RED-WHT/YEL

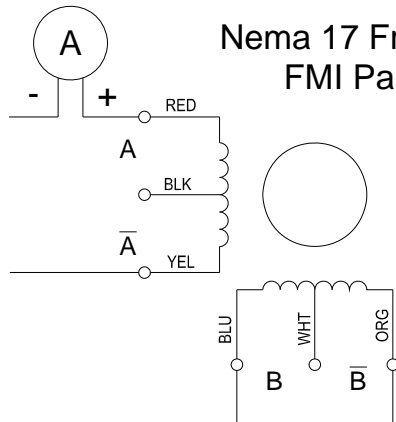

**Nema 17 Frame (1.7 inch square)
 FMI Part Number 110745**

** Adjust motor current trim pot as required.
 Do not exceed maximum motor rated current
 of 1.2 Amps per phase.

Pin # J1----POWER HEADER

Screw Terminal Color	Motor Phase	Motor Lead Connection
6 Yellow	A	Yellow
5 Red	A	Red
4 Brown	B	Orange
3 Orange	B	Blue

NOTE: Black no connection
 White no connection